

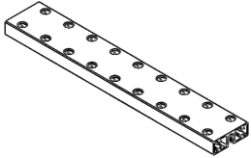

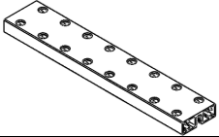







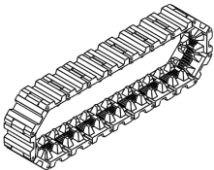





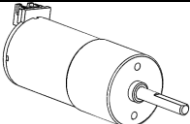

Parts list :

2X		Beam 0824-144
1X		Beam 0824-128
1X		Beam 0824-96
1X		Beam 0824-64
2X		Track x20
2X		Track Axle
2X		Threaded Shaft 4X31mm
6X		Screw M4X22
30X		Screw M4X14
4X		Countersunk Screw M3X8
10X		Nut M4
4X		Headless Screw M3X5
X2		Shaft Collar 4mm
2X		DC Motor-25

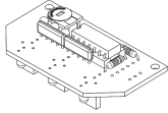
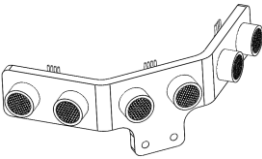
4X		Timing Pulley 90T
2X		Shaft Connector-4
2X		DC Motor-25 Bracket
1X		Axe121
1X		Head SR04x3
8X		Plastic Ring 4X7X2
4X		Flange Bearing 4X8X3mm
1X		Base Bracket power supply
1X		Base Bracket Arduino Leonardo
1X		Arduino proto shield R3
4X		Brass Stud M4X16
4X		Brass Stud M4X32
6X		1.2V battery

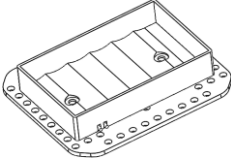
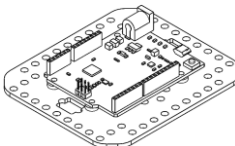
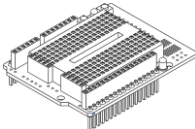
Assembly :

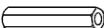
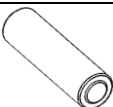
1

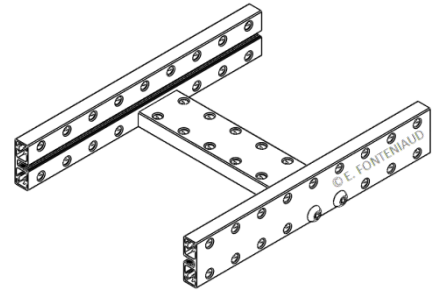
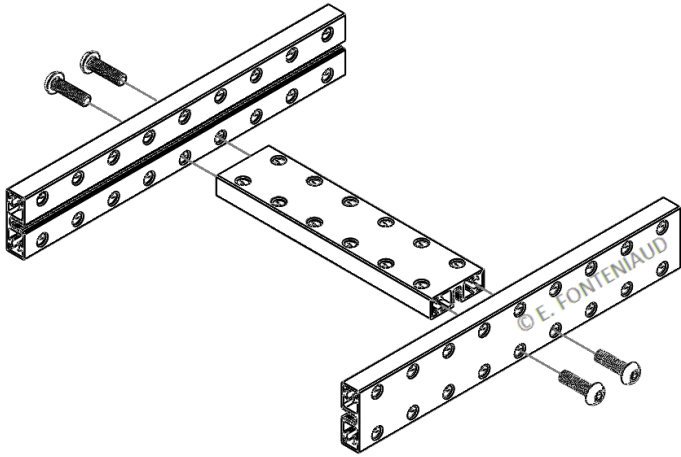

2X  Beam 0824-144

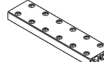
1X  Beam 0824-96

4X  Screw M4X14

2

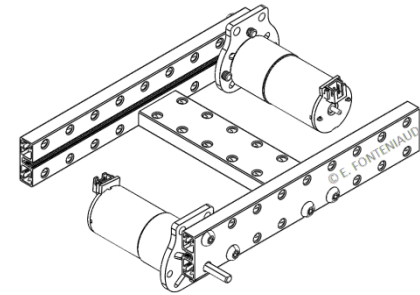
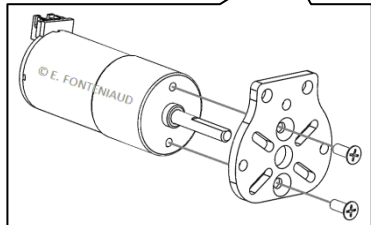
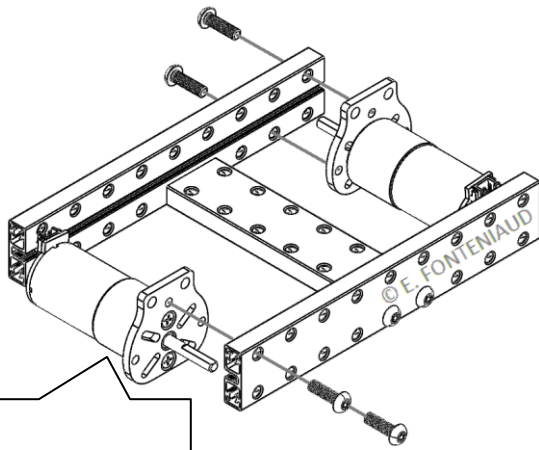

2X  DC Motor-25

2X  DC Motor-25 Bracket

4X  Screw M4X14

4X  Countersunk Screw M3X8

3

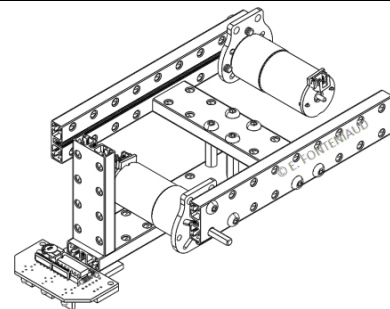
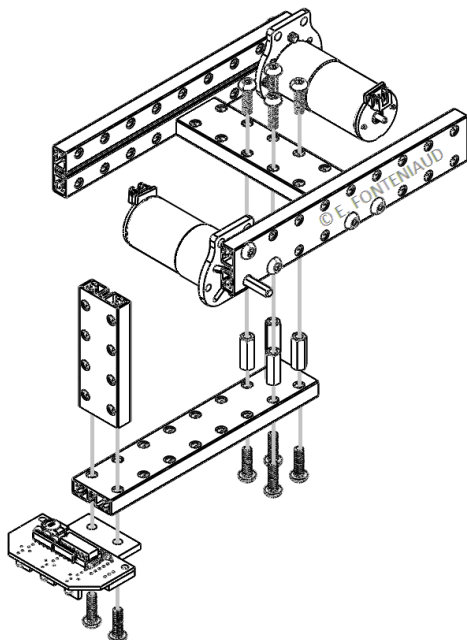

1X  Beam 0824-128

1X  Beam 0824-64

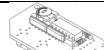



1X  Axe121

4X  Brass Stud M4X16

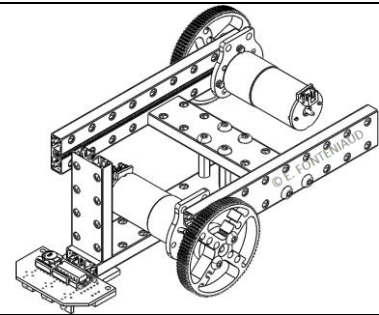
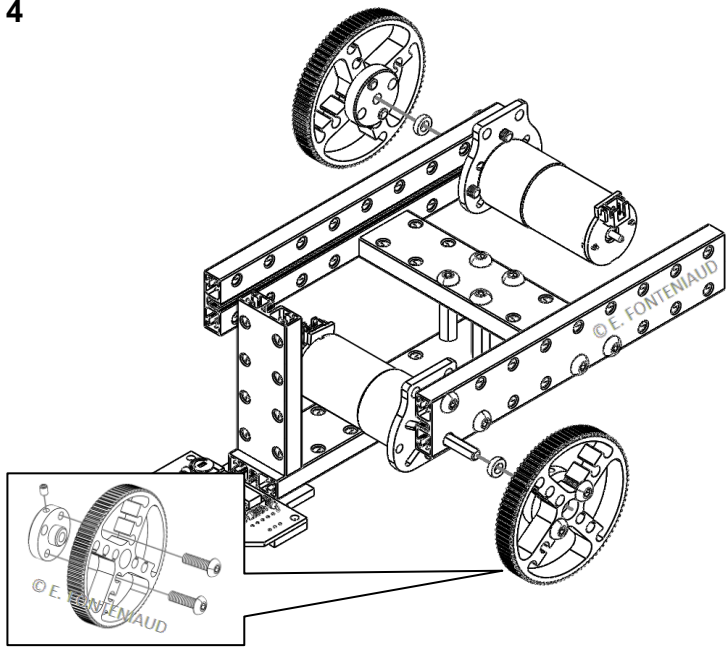
10X  Screw M4X14







4

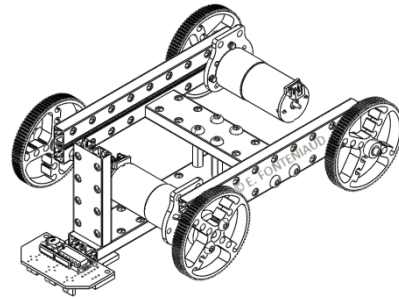
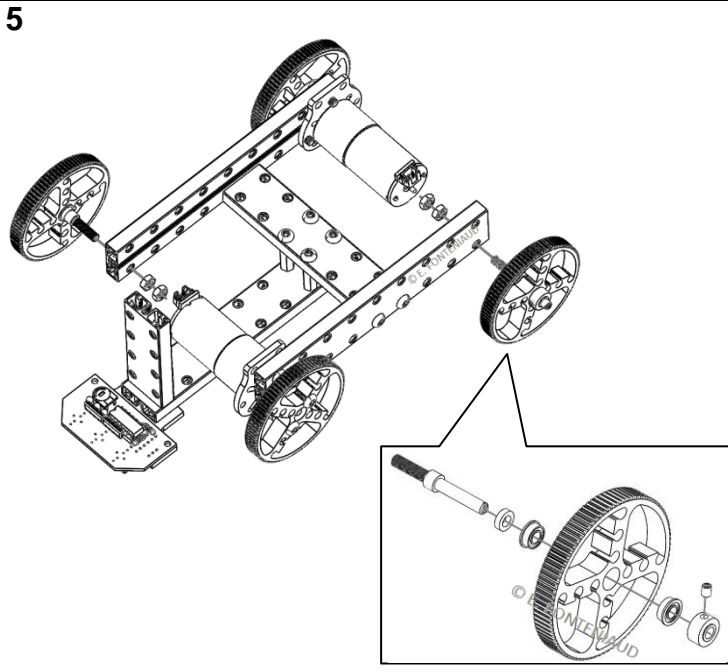

2X		Timing Pulley 90T
2X		Shaft Connector-4
4X		Screw M4X14
2X		Plastic Ring 4X7X2
2X		Headless Screw M3X5



5



2X		Timing Pulley 90T
2X		Threaded Shaft 4X31mm
2X		Plastic Ring 4X7X2
4X		Flange Bearing 4X8X3mm
2X		Shaft Collar 4mm
4X		Nut M4
2X		Headless Screw M3X5

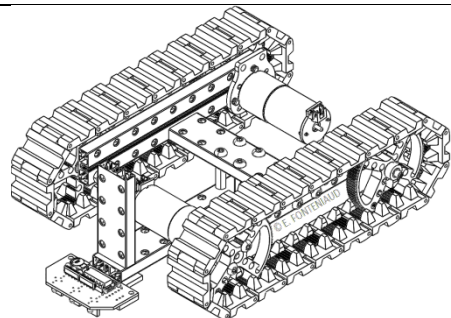
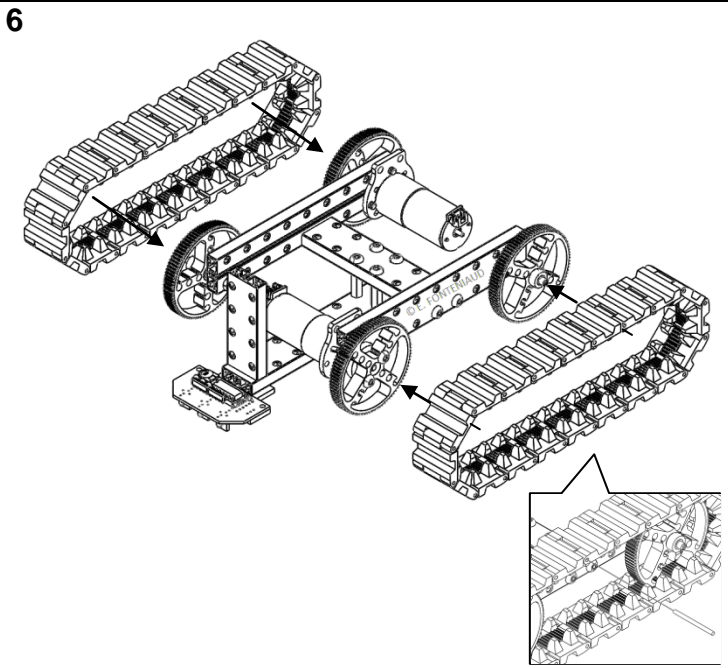

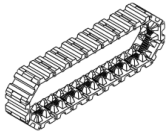



6

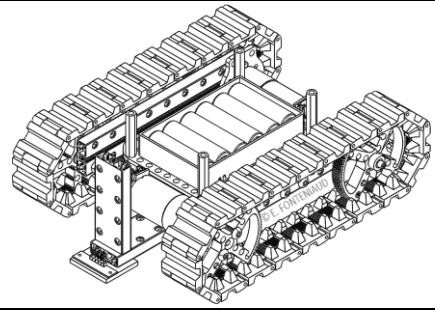
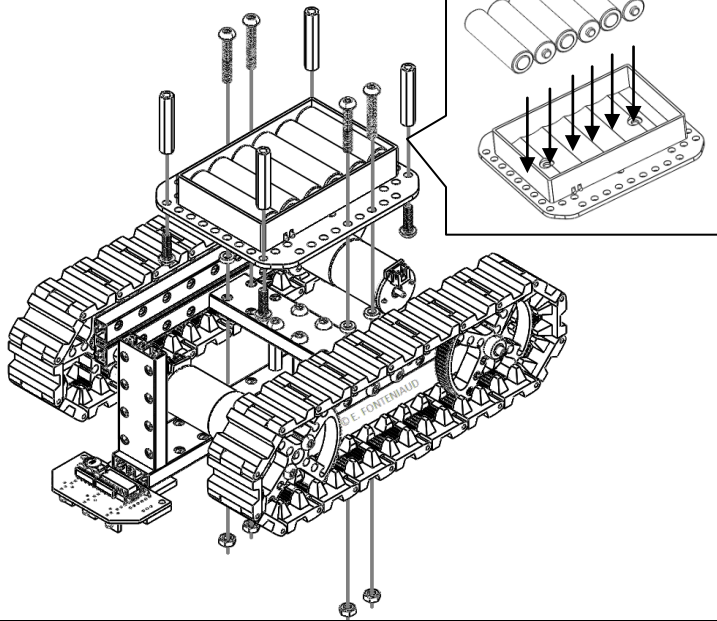

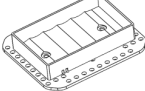
2X		Track x20
2X		Track Axle



7



1X		Base Bracket power supply
6X		1.2V battery
4X		Screw M4X22
4X		Screw M4X14
4X		Brass Stud M4X32
4X		Nut M4
4X		Plastic Ring 4X7X2

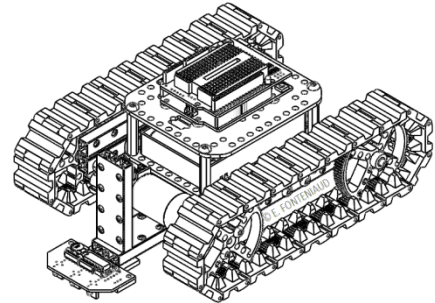
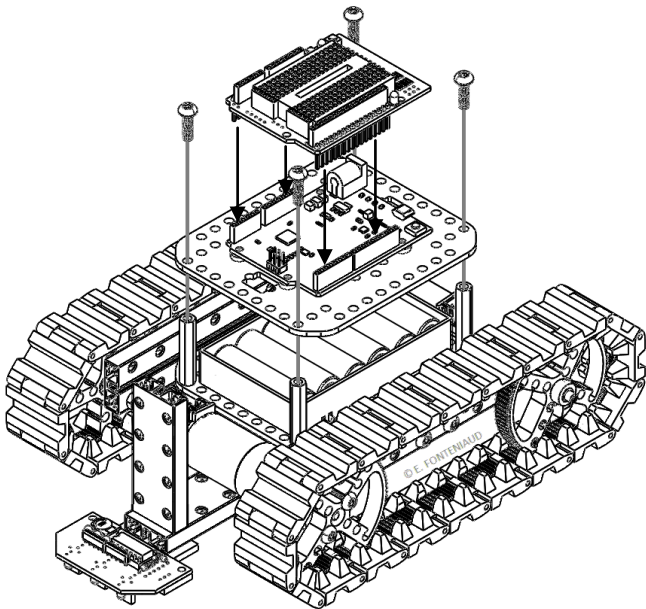

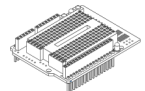
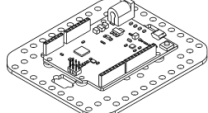
8

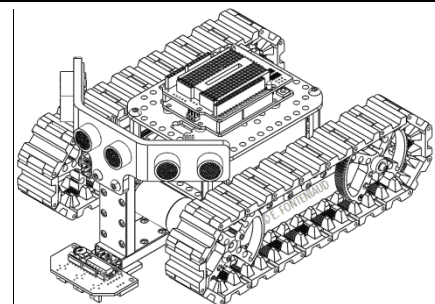
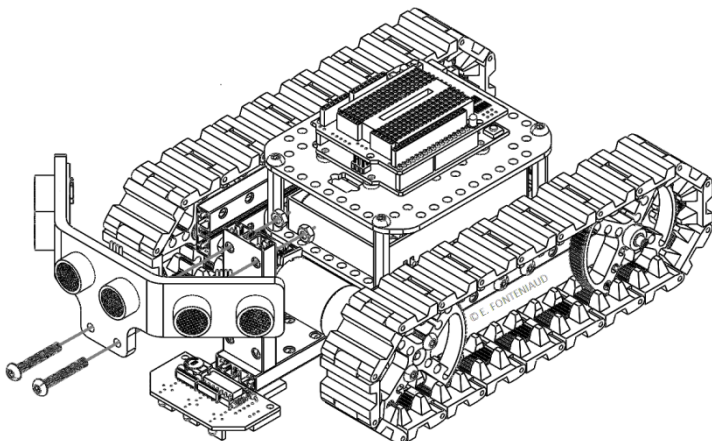

1X		Arduino proto shield R3
1X		Base Bracket Arduino Leonardo
4X		Screw M4X14

9

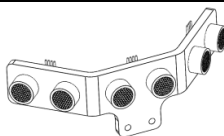

1X		Head SR04x3
2X		Screw M4X22
2X		Nut M4